

H10 – 200 – 86 – S..

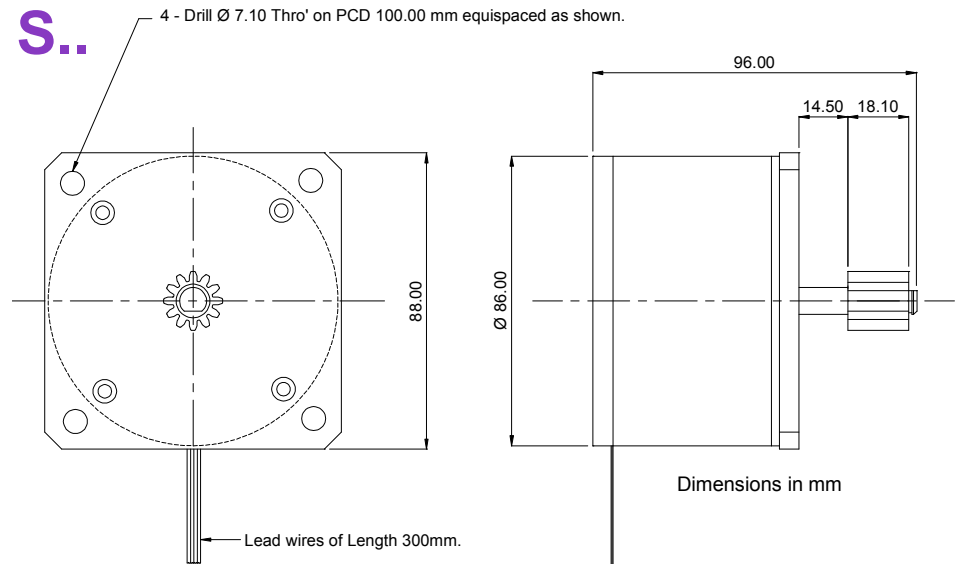
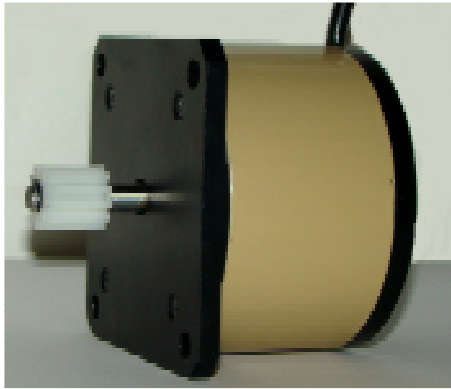

Features

- Pure Aluminium outer body for light weight
- UL approved insulations and winding wires for high reliability
- Superior bearings for long life
- High quality steel laminations for less power loss
- Higher torque in its class
- Class F insulation for better temperature control
- Reliability tested for longer life

SPECIFICATIONS		H10-200-86-S03
	Units	AC Synchronous Very high Torque
Operating Voltage	VAC	230
Resistance per phase	Ω	575
Inductance per phase	H	3.0
Power	W	38
Torque	Kgcm(oz-in)	> 10.5 (145.81)
Detent Torque	gcm(oz-in)	410 (5.69)
Rotor Inertia	g-m ²	68.5×10^{-3}
Weight	Kgs (oz)	1.30 (45.84)
Step Angle	degrees	1.8
Step angle accuracy	°	+/- 0.5°
Max. operating temperature	°C	90
Dielectric strength	-	< 10mA for 3000V for 1 min.
Insulation Resistance	M Ω	>1000 @ 1000V
Resistance for RC Phase Shifter	Ω	1K - 30W(40W for continuous operation)
Capacitance for RC Phase Shifter	μ F	1.30 440VAC PP

**For better torque or for change in resistance or any other specification including mounting plates, gears etc., please contact us. We can customize the motors for your applications.



PRECISION MOTORS

Principle of Operation

AC Synchronous motors are basically stepper motors that are modified for AC operations. This makes the synchronous motors inherit most features of the stepper motor. The most important feature is to provide rotation at a fixed speed in synchronization with the frequency of the power source, regardless of fluctuation of the load or line voltage. The speed is hence synchronized to the line frequency of 50 Hz. Also since they rotate at very low speeds of 60 rpm when connected to AC mains, their pull-out and pull-in torques are nearly equal and very high.

As synchronous motor actually is a bipolar stepper motor, we need two phases to drive the motor. These first phase is provided by the direct ac supply and the second by phase shifting the supply using suitable capacitors. This makes the driving circuit very simple and does not require a stepper controller or driver that is needed for a dc stepper motor.

Forward and reverse operations are achieved by alternating the phases. Hence the synchronous motor can rotate in both directions. Acceleration is achieved in a few steps and it stops accurately within a few degrees.

The circuit diagram for proper working of the motor is given below. For optimum performance, the recommended capacitors and resistors must be used. Since power consumed is 25W, for continuous operations, a higher wattage of resistance (typically 40W) is recommended to avoid heating of the resistor.

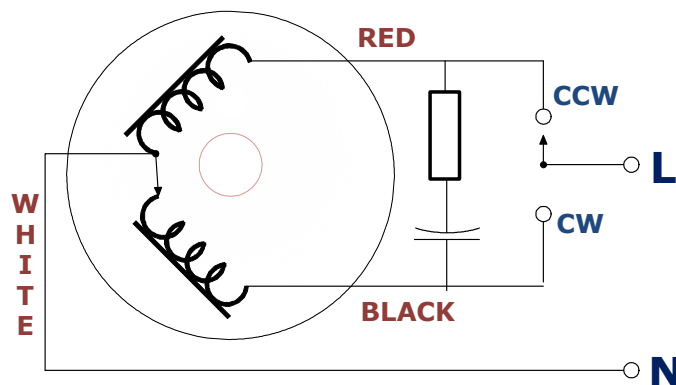

Precautions

- Since the motor works on 230V AC, ensure insulation of exposed leads
- Continuous operation heats the motor, and hence don't touch the motor
- Earthing of the motor or the entire system it is mounted is a must
- Torque at shaft is very high. Do not try to hold rotor with hand while it is running
- Don't run the motor above its max recommended temperature
- Do not operate if moisture or any other liquid falls on motor
- Handle motor carefully as it is heavy

